



Weigh Scale W210

PUBLISHED BY
Gallagher Group Limited
Kahikatea Drive, Private Bag 3026
Hamilton, New Zealand

www.gallagherams.com
Copyright© Gallagher Group Limited 2007.
All rights reserved. Patents Pending.

Weigh Scale W210 User Manual
3E2361 - Edition 2 - February 2014

DISCLAIMER: While every effort has been made to ensure accuracy, neither Gallagher Group Limited nor any employee of the company, shall be liable on any ground whatsoever to any party in respect of decisions or actions they may make as a result of using this information.

In accordance with the Gallagher policy of continuing development, design and specifications are subject to change without notice.

Developed and manufactured by Gallagher Group Limited, an ISO 9001:2000 Certified Supplier.

Table of Contents

Introduction	1
Care and maintenance	2
Installation	3
Installing the Weigh Scale bracket	3
Installing the loadbars	4
Installing the Weigh Scale	4
Power and batteries	5
Getting started	8
Loadbars	8
Weigh Scale	9
Units of Weight	9
Automatic Weighing	10
Overview	10
Using Automatic Weighing	11
Manual Weighing	12
Overview	12
Using Manual Weighing	12
Fine Weighing	13
Overview	13
Using Fine Weighing	13
At the end of the weighing session	13
Weight on Weigh Scale Memory	14
Zero Tracking	15
Loadbar and platform options	16
Gallagher Standard Loadbars	16
Gallagher Heavy Duty Loadbars	16
Gallagher Super Heavy Duty Loadbars	17
Gallagher Suspension Load Cell 250 kg	18
Gallagher Suspension Load Cell 500 kg	18
Specifications	19
Weigh Scale W210 Dimensions	19
General	19
Weight increments	20
Suspension load cell weight increments	21
Waste Electrical and Electronic Equipment	22

INTRODUCTION

Thank you for purchasing the Gallagher Weigh Scale W210 Weigh Scale. Gallagher Group Limited have been making agricultural weighing equipment for over 20 years and in that time have earned a reputation for quality equipment that withstands tough agricultural conditions.

The Gallagher Weigh Scale range of weighing systems is simple, tough, innovative and reliable.

All of the Weigh Scales in the Weigh Scale range can be matched to a choice of loadbar systems, as well as a range of platforms and crates to make an accurate and reliable weighing system.

Although designed specifically for agriculture, the Weigh Scale range is also suited to many industrial applications.

CARE AND MAINTENANCE

The Weigh Scale W210 is a tough and reliable product designed for use in typical livestock environments. However, proper care and maintenance can extend its life.

Listed below are guidelines for keeping the Weigh Scale in good condition:

- Don't submerge the Weigh Scale in any liquid.
- Store the Weigh Scale in a cool, dry place. Avoid storing it in direct sunlight
- After use, clean the Weigh Scale with a damp cloth. Take care not to scratch the display.
- Fit the connector caps to keep the connections clean and dry.

INSTALLATION

Installing the Weigh Scale bracket

The bracket can be mounted on a flat vertical surface, or on a round post.

To mount the bracket on a flat vertical surface, for example a square post or board, use the outer holes.

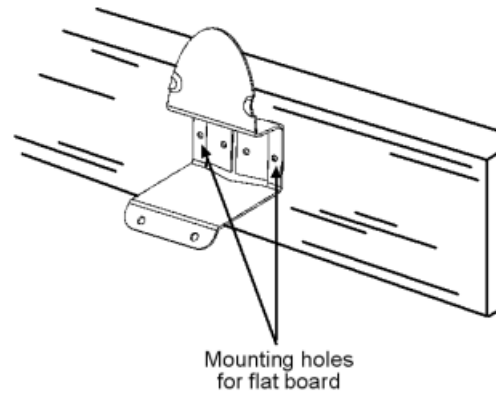

To mount the bracket on a round post, use the inner holes.

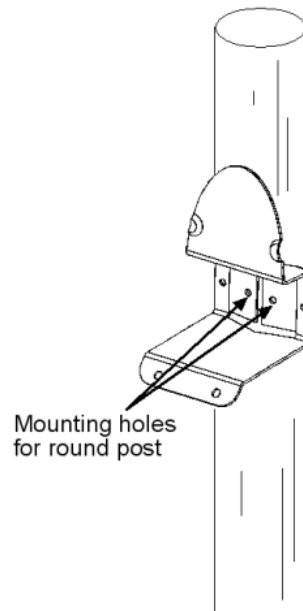

Don't mount the Weigh Scale bracket on the weighing crate or chute.

Installing the loadbars

To install the loadbars, follow these steps:

Note: Fit the loadbars as per the manufacturer's instructions.

1. Bolt the platform to the loadbars.
2. Ensure the platform is placed on a flat and level surface. Make sure it is not touching any rails or gates.
3. Either bolt the loadbars to the concrete pad or locate them on studs set into the concrete. This will prevent the platform from moving during the weighing session.
4. Connect the loadbar cables to the Weigh Scale.

Note: If you are using non Gallagher, loadbars ensure the loadbars are correctly calibrated.

Installing the Weigh Scale

The Weigh Scale can be placed on a table top or mounted on the Weigh Scale bracket supplied.

Position the Weigh Scale:

- clear of the platform to ensure it does not interfere with the flow of animals during the weighing cycle
- within easy reach of the loadbar leads
- within easy reach of the operator (for manual weighing), and
- in a well-lit area

POWER AND BATTERIES

During a weighing session, the Weigh Scale can be powered by its internal battery alone or by its internal battery and either the battery charger or an external 12 volt battery.

The battery charger connects between an AC outlet and the Weigh Scale.

If either the battery charger or an external 12 volt battery is connected to the Weigh Scale, the Weigh Scale's internal battery will be charged while the Weigh Scale is in use.

For optimum performance, switch off the Weigh Scale and charge its internal battery for at least five hours. When fully charged, the internal battery on its own will power the Weigh Scale continuously for a minimum of eight hours.

Charging the battery

The battery in the Weigh Scale can be recharged using either a battery charger or an external 12 volt battery.

Recharging the battery will take up to five hours depending on the level of charge already in the battery. The Weigh Scale can be in use or can be switched off while the battery is being charged.

Using the battery charger

To charge the battery using the battery charger, follow these steps:

1. Connect the lead between the battery charger and the Weigh Scale.



2. Plug the battery charger into an AC outlet and switch on.
3. Open the Weigh Scale case and make sure the battery charge icon  on the main screen is flashing. This indicates that the battery is charging and will be displayed whether the Weigh Scale is turned on or off.

Using an external 12 volt battery

To charge the Weigh Scale's internal battery using an external 12 volt battery, follow these steps:

1. Connect the supplied black and red battery leads to the Weigh Scale.
2. Connect the other end of the battery leads to the 12 volt battery.

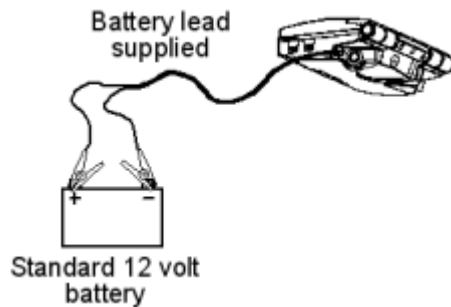



Connect the **Red** clip to the **Positive** terminal.

Connect the **Black** clip to the **Negative** terminal.

3. Open the Weigh Scale case and make sure the battery charge icon  on the main screen is flashing. This indicates that the battery is charging and will be displayed whether the Weigh Scale is turned on or off.

Battery charge status

The amount of charge left in the battery is shown by the battery icon located in the bottom left corner of the Weigh Scale's top screen.

Fully charged	
Partially charged	
Battery low	

The battery icon shows the charge level in the battery under these conditions.

- The Weigh Scale is switched on.
- The battery is not being charged.

While the battery is charging, the battery icon cycles between low and full charge.

Low battery warning

When the charge remaining in the battery drops to a very low level, the battery charge icon on the Weigh Scale will start to flash and four beeps will sound every 30 seconds. After about 15 minutes, the Weigh Scale will shut down.

Low voltage shutdown

When the battery charge drops to a critical level, the Weigh Scale will shut down. At this stage it is necessary to recharge the battery.

GETTING STARTED

For best performance, charge the internal battery for at least five hours before use.

To obtain the most accurate results:

- ensure that the animal is completely on the platform; and
- ensure that the underside of the platform is kept clear of stones, dung, etc.

Loadbars

- Bolt the platform to the loadbars.
- Ensure platform is placed on a flat and level surface, making sure it is not touching any rails or gates.
- To prevent the platform from moving during weighing, either bolt the loadbars to the concrete pad or locate them on studs set into the concrete.

Weigh Scale

1. Release the catches on the front of the Weigh Scale and open the case.
2. Either slide the Weigh Scale onto the bracket, or fold out the support stand and place the Weigh Scale on a flat surface.

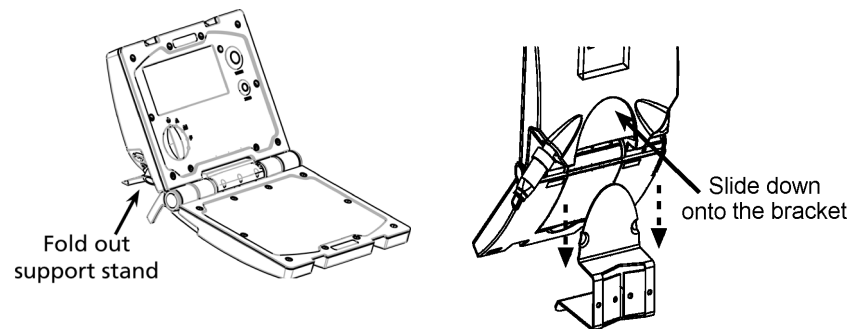

3. Connect the leads from both loadbars to the Weigh Scale.
4. If necessary, connect either the battery charger or an external 12 volt battery.
5. Select the weighing mode. The Weigh Scale W210 comes with three different weighing modes. To select the required weighing mode, rotate the mode select switch located on the left side of the Weigh Scale.

A is the automatic mode

M is the manual mode

F is the fine mode.

6. Press the blue **Zero** button to zero-out any weight that is on the platform.

Units of Weight

The Weigh Scale can display weights in either kilograms (kg) or pounds (lb).

To choose either unit of weight measure;

1. Turn the Weigh Scale off.
2. Hold down the green Weigh button and turn the Weigh Scale from Off to Fine Mode.
3. The word "Unit" will display on the screen.
4. Press the green Weigh button to toggle between "kg" and "lb".
5. When the unit of weight measure that you wish is being displayed, turn the Weigh Scale Off.
6. The unit of weight will be saved.

AUTOMATIC WEIGHING

Overview

Automatic mode is recommended for facilities that allow a smooth flow of animals across the platform.

In Automatic mode, the Weigh Scale starts weighing the animal as it steps onto the platform. After the Weigh Scale has determined an accurate weight, it will lock on to the measurement and display it on-screen. The weight will continue to display on-screen until the next animal steps onto the platform.

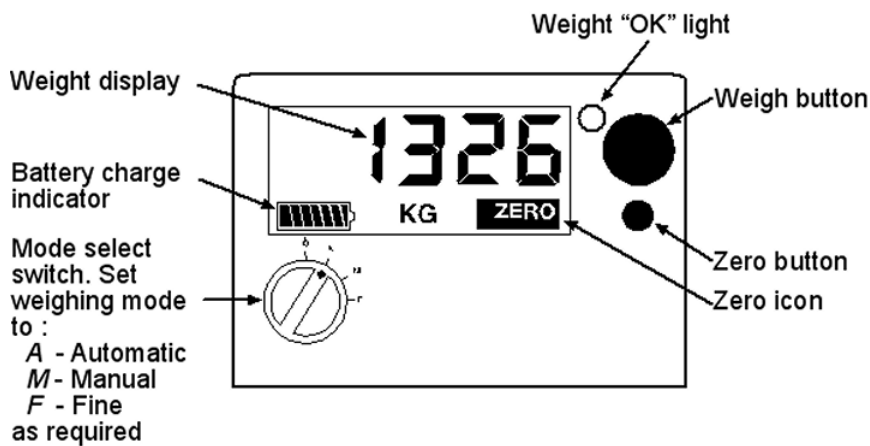

Using Automatic Weighing

1. Check that the mode select switch is set to **A**.
2. Check that the weight displayed is zero and that the **ZERO** icon is displayed. If it is not, press the blue **Zero** button.
3. Load the animal onto the platform. Ensure the animal is entirely supported by the platform — no hooves on the ground — and that no object is resting on the animal.
4. The Weigh Scale will automatically start weighing the animal. When the Weigh Scale has determined an accurate weight, it will lock on to the measurement and display it on-screen.

When the Weigh Scale has locked on:

- the measurement will remain on-screen;
 - the **Weight OK** light will glow;
 - **OK** will display on the screen; and
 - the Weigh Scale will beep.
5. If the weight has locked on and you want to re-weigh the animal, press the green **Weigh** button. The Weigh Scale will again weigh the animal and lock on to the measurement.
 6. Write down the weight of the animal if desired.
 7. Move the animal off the platform. The measurement will continue to display on-screen.
 8. The Weigh Scale will attempt to compensate for any accumulation of mud or dung left on the platform. If it is successful, the **ZERO** icon will display.
If the zero icon does not display, or it flashes, press the blue **Zero** button.
 9. Load the next animal onto the platform. The Weigh Scale will start weighing the animal as it steps onto the platform.

MANUAL WEIGHING

Overview

Manual mode is recommended for facilities that do not allow a smooth flow of animals across the platform or where the animals are restless. This mode allows the operator to decide when the measurement is made.

In Manual mode, the Weigh Scale starts weighing the animal after the operator presses the green **Weigh** button. When the Weigh Scale has determined an accurate weight, it will lock-on to the measurement and display it on-screen. The weight will continue to display on-screen until the green **Weigh** button is again pressed.

Using Manual Weighing

1. Check that the mode select switch is set to **M**.
2. Check that the weight displayed is zero and that the **ZERO** icon is displayed. If it is not, press the blue **Zero** button.
3. Load the animal onto the platform. Ensure the animal is entirely supported by the platform — no hooves on the ground — and that no object is resting on the animal.
4. Press the green **Weigh** button. After the Weigh Scale has determined an accurate weight, it will lock on to the measurement and display it on-screen.

When the Weigh Scale has locked on:

- the measurement will remain on-screen;
 - the **Weight OK** light will glow;
 - **OK** will display on the screen; and
 - the Weigh Scale will beep.
5. If the weight has locked on and you want to re-weigh the animal, press the green **Weigh** button. The Weigh Scale will again weigh the animal and lock on to the measurement.
 6. Write down the weight of the animal if desired.
 7. Move the animal off the platform. The measurement will continue to display on-screen.
 8. The Weigh Scale will attempt to compensate for any accumulation of mud or dung left on the platform. If it is successful, the **ZERO** icon will display.
If the zero icon does not display, press the blue **Zero** button.
 9. Load the next animal onto the platform.

FINE WEIGHING

Overview

Fine mode is recommended for weighing small static loads such as fleeces or produce. In Fine mode, the Weigh Scale uses finer weight increments and zero tracking is automatically switched off.

In Fine mode, the Weigh Scale operates like a bathroom scale. It displays the weight when a load is placed on the platform and displays zero when the load is removed.

Using Fine Weighing

1. Check that the mode select switch is set to **F**.
2. Check that the displayed weight is zero. If it is not, press the blue **Zero** button. This will reset the Weigh Scale to compensate for the weight of any dung or dirt that has accumulated on the platform.
3. Place the load onto the platform.
4. Write down the weight of the load if desired.
5. Move the load off the Weigh Scale. The weight indication should return to zero. If it does not, press the blue **Zero** button.

At the end of the weighing session

1. Switch the Weigh Scale off by turning the mode select switch to the  position.
2. Disconnect the loadbar cables.
3. Fit the protective caps to the loadbar cables.
4. Fit the protective caps to the Weigh Scale.

WEIGHT ON WEIGH SCALE MEMORY

The Weigh Scale will remember the weight on the platform at the time it is switched off. The weight will be restored to the display when the Weigh Scale is switched back on.

For example, suppose a wool bale is being packed on the platform and the Weigh Scale is turned off when the bale is half full. If the Weigh Scale is switched back on while the same bale is still on the platform, the Weigh Scale will remember the weight prior to being switched off and display the same weight.

ZERO TRACKING

During a weighing session, mud, dung and other matter can accumulate on the weighing platform. After each animal leaves the platform, the zero tracking feature attempts to compensate for the weight of this accumulation and, if it succeeds, sets the Weigh Scale to zero. If the accumulation weighs more than the Weigh Scale's zero tracking range, zero tracking will not work and the **ZERO** icon will flash.

To restore zero, press the blue **Zero** button.

If the Weigh Scale consistently fails to restore to zero, check that there are no obstructions under or around the platform or crate.

Note:

The zero tracking feature is enabled when the Weigh Scale is set to the Automatic and Manual modes. It is disabled when set to the Fine mode.

LOADBAR AND PLATFORM OPTIONS

It is recommended that you use Gallagher Loadbars with the Weigh Scale W210.

The Weigh Scale W210 Scale recognises most commonly available Loadbar sets. To connect to some Loadbar sets, adapter cables may be required.

If you are not using Gallagher Loadbars, a calibration check will be required prior to first use.

Gallagher Standard Loadbars

Features

- 2000 kg weighing capacity - Available in 600mm (23") and 1000mm (39") lengths
- Tough rugged steel loadbars
- Bottom feet mounting holes extend beyond top covers for ease of bolting down
- Slotted top mounting holes fit all sizes of platforms and crushes
- 6m (20') long tough loadbar cables fitted with high quality connectors
- Fully waterproof
- No rubber mounts

Talk to your Gallagher dealer about the best platform and/or crate for your requirements.

Gallagher Heavy Duty Loadbars

Features

- 3500 kg weighing capacity
- 1000 mm (39") rugged steel loadbars
- Bottom feet mounting holes extend beyond top covers for ease of bolting down
- 6 m (20') long tough loadbar cables fitted with high quality connectors
- Fully waterproof
- No rubber mounts
- High capacity load cells withstand large shock loads
- Heavy steel chassis construction absorbs the harshest of impacts

- Set them and forget them for permanent installation under large crushes.

Talk to your Gallagher dealer about the best platform and/or crate for your requirements.

Gallagher Super Heavy Duty Loadbars

Features

- 4500 kg weighing capacity
- 1000 mm (39") rugged steel loadbars
- Bottom feet mounting holes extend beyond top covers for ease of bolting down
- 6 m (20') long tough loadbar cables fitted with high quality connectors
- Fully waterproof
- No rubber mounts
- High capacity load cells withstand large shock loads
- Heavy steel chassis construction absorbs the harshest of impacts
- Set them and forget them for permanent installation under the largest crushes

Talk to your Gallagher dealer about the best platform and/or crate for your requirements.

Gallagher Suspension Load Cell 250 kg

Features:

- 250 kg capacity loadcells
- Replaces mechanical scale for hanging crates
- Compact sturdy design
- No rubber to delaminate or rot
- Spiral spring metal reinforced cable
- High quality moisture proof connectors

Gallagher Suspension Load Cell 500 kg

Features:

- 500 kg capacity loadcells
- Replaces mechanical scale for hanging crates
- Compact sturdy design
- No rubber to delaminate or rot
- Spiral spring metal reinforced cable
- High quality moisture proof connectors

SPECIFICATIONS

Weigh Scale W210 Dimensions

	Metric	Imperial
Length	232 mm	9.25"
Width	212 mm	8.5"
Height	90 mm	3.5"
Weight	2 kg	4.4 lb

General

Operating Temperature	-20° to 50° C -5° to 120° F
Accuracy	± 1%
Environmental Protection Rating	IP65
Input Voltage	11 - 14 VDC

Not for trade

This Weigh Scale is not certified "Legal for Trade".

Weight increments

For Gallagher Loadbar sets, the weight increments are preset as shown in the table. For other loadbar sets talk to your Gallagher dealer.

Weight Range	Gallagher Standard Loadbars (2000 kg)	Gallagher Heavy Duty Loadbars (3500 kg) and Gallagher Super Heavy Duty Loadbars (4500 kg)
--------------	---	---

Automatic or Manual modes:

0 - 49.9 kg	200 g increments	500 g increments
50 - 199.9 kg	500 g increments	500 g increments
200 - 499.9 kg	1 kg increments	1 kg increments
500 - 1999.9 kg	2 kg increments	2 kg increments
2000 - 4999.9 kg	Not Applicable	5 kg increments

Fine mode:

0 - 49.9 kg	100 g increments	200 g increments
50 - 199.9 kg	500 g increments	500 g increments
200 - 499.9 kg	1 kg increments	1 kg increments
500 - 1999.9 kg	2 kg increments	2 kg increments
2000 - 4999.9 kg	Not Applicable	5 kg increments

Suspension load cell weight increments

For a suspension load cell, the weight increments are preset as shown in the table.

Weight Range	Gallagher Suspension Load cells (250 & 500 kg)
---------------------	---

Automatic or Manual modes:

0 - 49.9 kg	200 g increments
50 - 499.9 kg	500 g increments
500 - 1999.9 kg	2 kg increments

Fine mode:

0 - 49.9 kg	100 g increments
50 - 499.9 kg	500 g increments
500 - 1999.9 kg	2 kg increments

WASTE ELECTRICAL AND ELECTRONIC EQUIPMENT

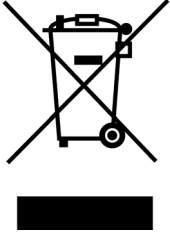

This symbol on the product or its packaging indicates that this product must not be disposed of with other waste. Instead, it is your responsibility to dispose of your waste equipment by handing it over to a designated collection point for the recycling of waste electrical and electronic equipment. The separate collection and recycling of your waste equipment at the time of disposal will help conserve natural resources and ensure that it is recycled in a manner that protects human health and the environment. For more information about where you can drop off your waste equipment for recycling, please contact your local city recycling office or the dealer from whom you purchased the product.